



International Journal of Marketing Management

ISSN 2454 - 5007



www.ijmm.net

Email ID: editor@ijmm.net , ijmm.editor9@gmail.com

A Novel Control Scheme for Wind Turbine Driven DFIG Interfaced to Utility Grid

D.Ramesh¹, ADivya², M. Nagalakshmi³

¹Associate Professor, Department of EEE, BRILLIANT GRAMMAR SCHOOL EDUCATIONAL SOCIETY'S GROUP OF INSTITUTIONS-INTEGRATED CAMPUS Abdullapurmet (V), Abdullapurmet (M), R.R Dt. Hyderabad.

²Assistant Professor, Department of EEE, BRILLIANT GRAMMAR SCHOOL EDUCATIONAL SOCIETY'S GROUP OF INSTITUTIONS-INTEGRATED CAMPUS Abdullapurmet (V), Abdullapurmet (M), R.R Dt. Hyderabad.

³UG Student, Department of EEE, BRILLIANT GRAMMAR SCHOOL EDUCATIONAL SOCIETY'S GROUP OF INSTITUTIONS-INTEGRATED CAMPUS Abdullapurmet (V), Abdullapurmet (M), R.R Dt. Hyderabad.

ABSTRACT:

This article deals with a phase-locked loop (PLL)- based novel control for wind turbine driven doubly fed induction generator interfaced to utility grid with a battery energy storage (BES) connected at the dc link. The control of grid-side converter (GSC) is modified to export/import constant power to/from the grid. The state of charge of BES helps in deciding the reference export power to the grid apart from the manual selection using averaged wind power in a particular period of time. An off maximum power point tracking logic is incorporated in the rotor-side converter (RSC) control to operate the BES within its constraints and, moreover, to feed constant power to the grid. In addition, the energy management scheme of the system is presented in the form of flowchart for both exporting and importing power to/from the grid. The RSC and GSC have taken care of unity power factor operation at stator terminals and to mitigate harmonics and grid currents balancing, respectively. The system performance is found robust as the PLL response is not affected even under grid voltages with dc offset. The system is modeled and simulations are carried out in MATLAB using Sim Power Systems tool box. Moreover, the control scheme performance is compared with conventional control

algorithms both in terms of PLL and converter controls. To validate the effectiveness of the control scheme, a prototype of the system is developed. Test results demonstrate the satisfactory performance of the system under various operating conditions.

Keywords: *MATLAB, RSC, GSC, PLL, Grid, BES.*

1. INTRODUCTION

whole world depends on the renewable energy sources. Wind energy is a clean and eco-friendly renewable energy resource, which reduces dependency from fossil fuels. Wind energy system plays a very significant role to become more reliable renewable energy source across all over the world. The demand of wind energy increases gradually. At the end of 2020; it is expected that demand of wind power may be reaches up to 75 GW [1]. In fixed wind speed systems squirrel-cage induction generators are used, which is directly connected with grid system [4] as in case of variable wind speed [2]-[18]. This review paper focused on actual position of the rotor and speed sensorless control method operation in autonomous DFIM based wind energy generation system [19]-[37]. In such system to control the

variable-speed operation direct voltage control methods [37]-[55]; stator flux oriented control methods [72]-[74]; and MRAS observer based methods [90]-[103] are used. For higher wind velocity, active pitch angle control method is used to overcome the generated aerodynamic power by changing the actual position of rotor blades through suitable angle from wind direction. To resolve the problem of high wind speed operation, wind turbines are fabricated using power control scheme. Primary techniques used for power control [21] in wind turbines systems are: - a) Pitch controlled b) Stall controlled c) Active stall controlled d) Yaw controlled. In case of pitch controlled wind turbine system an electronic regulator is used for continuous observation of wind turbine

output power. An actuating signal is generated.

when the output power cross the threshold limit and send this actuating signal to the blade pitch mechanism for immediately pitching (turning) the rotor blades marginally out of the wind. On the other hand when the output power again within the threshold limit due to moderate or low wind speed, the blade pitch mechanism again turning or pitching back the turbine blades in the direction of wind. Thus turbine blades are capable enough to move or turn pitch with reference to their longitudinal axis. Normally at a time, a small degree of turn will be given to the turbine for moving rotor blades in case of pitch controlled wind turbines. In stall controlled based wind turbines; the rotor blades bolted on head of the hub with a fixed angle. In stall controlled wind energy system, moving towards its longitudinal axis, the rotor blades distort fairly. The output power is controlled through the design of rotor blades. In case of 1 MW &

above rated wind energy systems, active stall control is preferred more. It is quite similar as pitch controlled mechanism, having pitchable blades operate through either hydraulics or electric stepper motors. In case of active stall control, the output power is more precise as obtained in case of passive stall. The machine can also be run near to rated power for every permissible wind speeds.

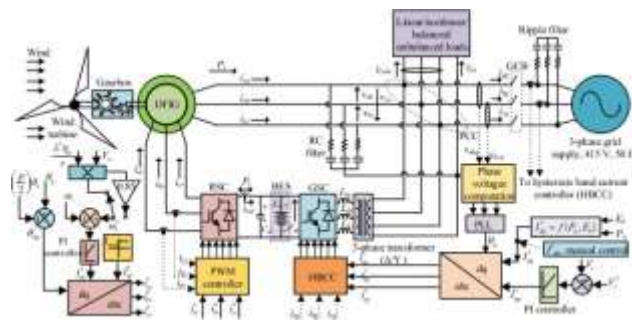

Fig.1. Block diagram.

2 LITERATURES SERVEY

Wind industry is becoming one among the world’s fastest growing energy sectors nowadays, offering the simplest opportunity to unlock a replacement era of environmental protection, helping to satisfy global energy demand and starting the

transition of sustainable energy to a worldwide economy. Variable speed constant frequency operation, reduced flicker and independent control capabilities for active and reactive powers are often achieved by Wind turbines supported doubly fed induction generators have attracted particular attention due to their advantages. Active power from the generator is decided by the turbine control and must in fact be within the potential of the turbine generator system. The development caused by doubly fed induction generator features a good performance without losing any equilibrium when the voltage reduction occurs in these conditions; it will remain connected to the power system. DFIGs are variable speed generators with controlled power electronic converters are used for improving the efficiency and power quality. The main components of a wind turbine system that including the turbine rotor, gearbox, generator, transformer and possible power electronics. Wind turbines

capture the power from the wind and convert it to rotating mechanical power, which successively converted into electric power by alternator/ generator.

RECOMMENDED SYSTEM:

Figure 1 shows the block diagram for the overall control strategies including two parts of DFIG-WECS. The primary part is that the electrical control system of DFIG, which incorporates control of the RSC and the GSC. The target of the RSC is to permit the DFIG wind turbine for decoupled control of active and reactive power or speed. The most objective for the grid-side converter is to stay the dc link voltage constant it's possible to regulate the torque or the speed of the DFIG and therefore the power factor at the stator terminals by the machine-side converter. The second part is that mechanical control system of the wind turbine having the important objective to be the capture of wind generation maximization and minimization of transient low speed shaft loads. The RSC control scheme including

the inner and outer control loops. The outer control loops have two PI controllers, which are used to regulate the stator reactive and active power independently, whereas the inner ones have two PI controllers, which are used to regulate the d-axis and q-axis rotor currents independently. The GSC is connected between the DC-link and therefore grid via the filter. The main objective is to take care of the DC-link voltage at a given value and to manage the reactive power flow between the GSC and therefore the grid. The GSC is typically operated at unity power factor, but it is often used for voltage support during the grid fault by injecting reactive power into the grid. Most doubly-fed electric machines in industry today are three-phase wound-rotor induction machines that contain the stator and the rotor windings. Doubly-fed electric machines are basically electric machines with a back-to-back converter are often seen in Figure 1. The back-to-back converter consists of two converters i.e

machine-side converter and grid-side converter. DFIG are that they permit the amplitude and frequency of their output voltages to be maintained at a permissible value.

3. OVER VIEW OF PROPOSED SYSTEM

The energy management scheme of the system both for export and import of grid power is depicted in Fig. 1 in the form of flowchart. It is to be noted that if utility electricity price is low, then the system can import power from the grid and activates the right half of the flowchart. However, most of the times, the system exports power to the grid and, therefore, it activates the left half of the flowchart. Here, the effective power is defined as the maximum wind power (P_w) minus the grid power (P_G) and minus the load power (P_L) as follows: $P_{eff} = P_w - P_G - P_L$. (31) Now, different cases present in the left half of the flowchart and the limitation of the system

and situations that the system cannot feed constant power to the grid are as follows.

1) Case A: If $P_{eff} > 0$, it means that the wind generation is more than the combined export grid power and the load power. In this, if battery SOC is not at its maximum value and maximum charging power, $P_{mxcharge}$ is less than the P_{eff} then action is to inject maximum power to BES and at the same time to avoid over charging, an action is to deviate from wind MPPT (off-MPPT) or an increase PG export. So here, the system operator takes the decision either to export more power to the grid or operate the wind turbine in off-MPPT mode.

2) Case B: If $P_{eff} > 0$ and $SOC = SOC_{mx}$ then BES stays at idle and at the same time, an action is to operate the wind turbine in off-MPPT mode or an increase PG export. Here, SOC_{mx} represents the maximum SOC of BES.

3) Usual Scenario: If $P_{eff} > 0$ and if battery SOC is not at its SOC_{mx} and $P_{mxcharge} >$

P_{eff} then the action is to charge the BES and operate the wind turbine in MPPT mode. Moreover, in this case, the grid power is regulated at constant value without any change. Moreover, if $P_{eff} < 0$ and if battery SOC is not at its SOC_{mn} and $P_{mx discharge} > |P_{eff}|$ then BES discharges and at the same time, an action is to operate the wind turbine in MPPT mode. Moreover, the grid power remains unchanged. The SOC_{mn} and $P_{mx discharge}$ denote the minimum SOC and maximum discharge power of the battery, respectively.

4) Case C: If $P_{eff} < 0$ and battery SOC is not at its minimum value and $P_{mx discharge} < |P_{eff}|$ then the action is to extract maximum power from BES and at the same time to avoid deep discharging, an action is to decrease PG export or load shedding. So, here the system operator takes the decision either to decrease PG export or to initiate load shedding.

5) Case D: If $P_{eff} < 0$ and $SOC = SOC_{mn}$ then the BES stays idle and at the same time, an action is to decrease PG export or initiate load shedding. It is observed from the aforementioned cases that off-MPPT is initiated in case A and case B only. In all other cases, the wind turbine is operated in MPPT mode. Moreover, the grid power is regulated at constant value in usual scenario. But there is a possibility of an increase/a decrease in export PG in cases A–C. However, if one wants to maintain the constant power in the grid, then initiate the off-MPPT for cases A and B and load shedding for cases C and D.

4. SIMULATION RESULTS:

The modelling and simulation of grid-interfaced WECS are carried in MATLAB by utilizing the Sim Power Systems toolbox for various scenarios such as wide variation in wind speed considering turbulence, nonlinear unbalanced loads, change in grid reference power, and comparative analysis of the

control algorithms over conventional controls. The different signals used to demonstrate the system performance are wind power (P_w), stator power (P_s), rotor power (P_r), grid power (P_G), rotor dlink current (i_{rdc}), battery power (P_b), dc-link voltage/battery voltage (V_{dc}), load power (P_L), stator voltages (v_s, v_{sa}), stator currents (i_s, i_{sa}), rotor currents (i_{rabc}), grid currents (i_g, i_{ga}), load currents (i_{La}, i_{Lb}, i_{Lc}) and GSC currents (i_{ca}, i_{cb}, i_{cc}), pu stator voltages (v_{spu}), and dc offset voltages (v_s -dc offset). The simulation parameters are given in Appendix A. It is to be noted that wind power (P_w) is the algebraic sum of stator and rotor powers.

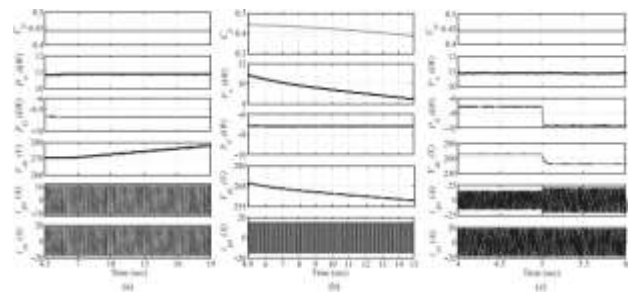

Depicts the effectiveness of the control scheme for both RSC and GSC over the conventional control algorithm. Fig. 9(a) illustrates the waveforms of C_p ,

P_w , P_G , V_{dc} , i_{ga} , and i_{sa} at wind speed of 9 m/s for conventional control algorithm. Moreover, the grid power is regulated at 7.12 kW..

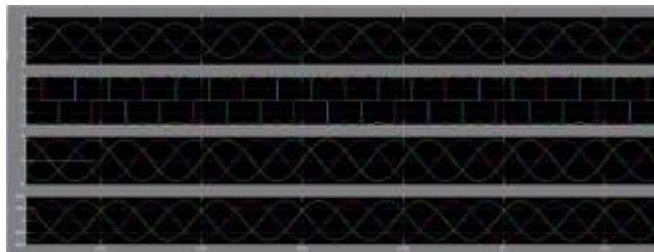

Fig.2. Output results at grid power.

The system is operating at wind MPPT, and the total wind power (P_w) extracted is nearly equal to 11 kW. Therefore, remaining power is continuously fed to BES for charging and it increases the BES voltage beyond the maximum limit, i.e., 270 V. This higher voltage across the dc link results in lower modulation index for RSC and increases the harmonics in the rotor winding of DFIG. Similarly, the lower generation results in deep discharging of the BES and crosses the lower voltage limit. Therefore, in conventional controls, there is a problem of deep discharging and charging of the BES

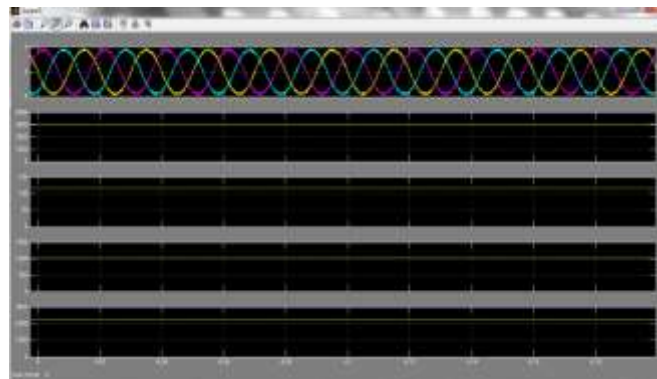

Fig.3. DFIG generator output.

CONCLUSION:

The PLL-based novel control scheme has been used for a grid interfaced wind driven DFIG system with a BES at dc link. The tip-speed ratio MPPT method has been adopted into the control scheme to extract maximum power as well as to operate in off-MPPT mode in order to operate BES within the limits. Simulated results have displayed the fairly good performance of the system under wide varying wind speed considering turbulence, nonlinear unbalanced load connected at PCC, and the change in export grid reference power. Moreover, the effectiveness of the control scheme has been compared with conventional controls. The performance of BES has been found

satisfactory in achieving grid power smoothening. Moreover, PLL performance is found stable even with dc offset. Test results have demonstrated the effectiveness of GSC in compensating the harmonics and regulating grid active power during export and import conditions. Moreover, the RSC is controlled effectively to achieve unity power factor at stator terminals. Moreover, the system performance is found satisfactory under variable wind speeds and change in load scenarios.

REFERENCES

- [1] Y. Zhou, L. Zhao, and W. Lee, “Robustness analysis of dynamic equivalent model of DFIG wind farm for stability study,” *IEEE Trans. Ind. Appl.*, vol. 54, no. 6, pp. 5682–5690, Nov./Dec. 2018.
- [2] K. Ni, Y. Hu, G. Chen, C. Gan, and X. Li, “Fault-tolerant operation of DFIG-WT with four-switch three-phase grid-side converter by using simplified SVPWM technique and compensation schemes,” *IEEE Trans. Ind. Appl.*, vol. 55, no. 1, pp. 659–669, Jan./Feb. 2019.
- [3] Y. Zou, M. E. Elbuluk, and Y. Sozer, “Simulation comparisons and implementation of induction generator wind power systems,” *IEEE Trans. Ind. Appl.*, vol. 49, no. 3, pp. 1119–1128, May/Jun. 2013.
- [4] C. Wu and H. Nian, “Stator harmonic currents suppression for DFIG based on feed-forward regulator under distorted grid voltage,” *IEEE Trans. Power Electron.*, vol. 33, no. 2, pp. 1211–1224, Feb. 2018.
- [5] R. M. Prasad and M. A. Mulla, “A novel position-sensorless algorithm for field-oriented control of DFIG with reduced current sensors,” *IEEE Trans. Sustain. Energy*, vol. 10, no. 3, pp. 1098–1108, Jul. 2019.
- [6] S. Puchalapalli and B. Singh, “A single input variable FLC for DFIG based WPGS in standalone mode,” *IEEE Trans. Sustain. Energy*, to be published. doi: 10.1109/TSTE.2019.2898115.

- [7] S. Kumar Tiwari, B. Singh, and P. K. Goel, “Design and control of microgrid fed by renewable energy generating sources,” *IEEE Trans. Ind. Appl.*, vol. 54, no. 3, pp. 2041–2050, May/Jun. 2018.
- [8] L. Wang and L. Y. Chen, “Reduction of power fluctuations of a large-scale grid-connected offshore wind farm using a variable frequency transformer,” *IEEE Trans. Sustain. Energy*, vol. 2, no. 3, pp. 226–234, Jul. 2011.
- [9] V. C. Ganti, B. Singh, S. K. Aggarwal, and T. C. Kandpal, “DFIG-based wind power conversion with grid power leveling for reduced gusts,” *IEEE Trans. Sustain. Energy*, vol. 3, no. 1, pp. 12–20, Jan. 2012.
- [10] X. Y. Xiao, R. H. Yang, X. Y. Chen, Z. X. Zheng, and C. S. Li, “Enhancing fault ride-through capability of DFIG with modified SMES-FCL and RSC control,” *IET Gener., Transmiss. Distrib.*, vol. 12, no. 1, pp. 258–266, Jan. 2018.